

CUSTOMISED FLANGE TIGHT FLAT RUBBER GASKET WITH TAIL (NORIKA) FOR POTABLE WATER

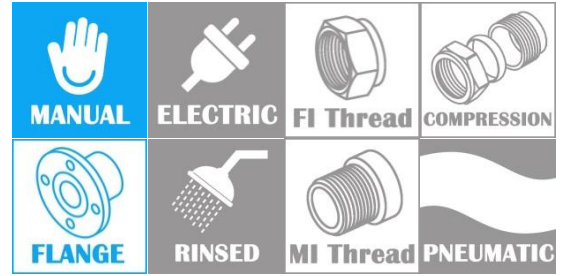

COMPLY WITH SS270:2015
SS375:2015

- COMPATIBLE WITH BS4504 PN16 FLANGES
- PATENT PENDING

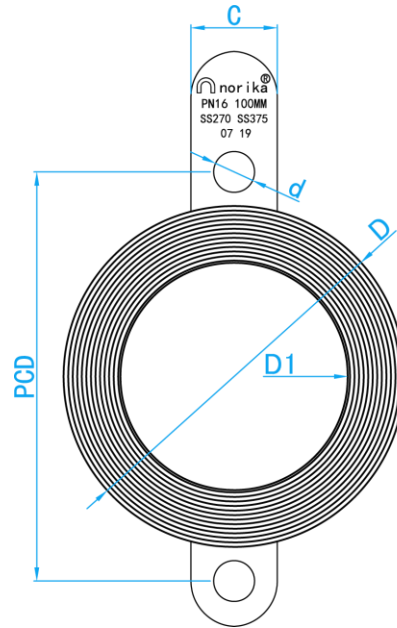

TOP VIEW

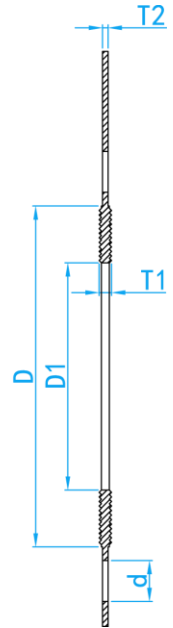

CROSS SECTIONAL VIEW

STANDARD SPECIFICATIONS

MATERIAL	EPDM
RUBBER HARDNESS	66-75
OPERATING TEMPERATURE	-15~+115°C

DIMENSIONS

SKU	SIZE (mm)	D1 (mm)	PCD (mm)	Nos OF HOLES	d (mm)	D (mm)	T1 (mm)	T2 (mm)	WEIGHT (kg)	PCS/CTN
RFGN050PUB*	50	50	125	2	18	94	4.4	2.2	0.038	250
RFGN065PUB*	65	65	145	2	18	113	4.4	2.2	0.050	200
RFGN080PUB*	80	80	160	2	18	130	5.5	2.5	0.080	200
RFGN100PUB	100	100	180	2	18	150	5.5	2.5	0.090	150
RFGN150PUB	150	150	240	2	22	214	6.0	2.5	0.155	100
RFGN200PUB*	200	200	295	2	22	264	7.2	4.5	0.250	35
RFGN250PUB*	250	250	355	2	26	314	7.2	4.5	0.320	35
RFGN300PUB*	300	300	410	2	26	372	7.2	4.5	0.380	25

*This item requires special ordering. Please consult with a salesperson for the estimated lead time.